

# RLE01-2M

## electric energy meters





- **Meters for measuring and monitoring AC electric energy consumption in 1-phase network - 230 V**
- Bi-directional indication of total active energy consumption/transfer (kWh) and power (W) • Real-time measurement, intelligent monitoring
- Large and readable LCD display
- Remote data reading via ModBus RTU (RS-485)
- AC input voltages • Cover - modular, width 36 mm
- Direct mounting on 35 mm rail mount acc. to EN 60715
- Applications: commercial and industrial applications in photovoltaic networks (for solar inverters)
- Compliance with standard EN 50470
- Recognitions, certifications, directives: RoHS, MID 

### Input circuit

Rated input voltage	AC	230 V +/-10%
Operating range of supply voltage		0,8...1,2 U <sub>n</sub>
Input current		
• direct input (I <sub>min.</sub> / I <sub>max.</sub> )		0,25 A / 63 A
• direct input (I <sub>tr</sub> / I <sub>st</sub> )		0,5 A / 0,02 A
• CT (I <sub>n</sub> / I <sub>max.</sub> )		1,5 A / 6 A
Inrush current		
• direct input		0,002 I <sub>b</sub>
• CT		0,001 I <sub>n</sub>
Energy consumption		
• voltage circuit		< 4 VA
• current circuit		< 1 VA
Supply frequency	AC	50/60 Hz

### Output/measuring circuit

Real-time measurement		voltage, current, active/reactive current, active/reactive/positive power, power factor, frequency, demand, max./min. values
Energy measurement		bi-directional active/reactive energy, four-quadrant reactive energy, apparent energy
Communication		
• communication interface		RS-485 port 
• protocol		ModBus RTU  or DL/T645, transmission rate up to 9600 bps
Accuracy		
• measuring accuracy of device		class B index
• voltage current		class 0,2
• power, active energy		class 0,5 s
• reactive energy		class 2
Electrical impulse		1 active energy pulse output, pulse width 80 ms ±20%
RTC measurement error		≤ 0,5 s/day
<b>General data</b>		
Dimensions (L x W x H)		90 x 36 x 63 mm
Weight		270 g (with packaging)
Ambient temperature	• storage	-30...+80 °C
(non-condensation and/or icing)	• operating	-25...+70 °C
Cover protection category		panel: IP 54      cover: IP 20      EN 60529
Relative humidity (non-condensation)		5...95%

 RS485 port is isolated from the inside of the meter, and there is anti overvoltage protection circuit in the meter

RS-485 communication is realized through PC to programming, setting and reading meters.

 Communication protocol is defaulted as ModBus RTU.

# RLE01-2M

## electric energy meters

### EMC according to Directive 2014/30/EU

Immunity to:	EN 55035
• electrostatic discharge (IEC 61000-4-2)	IV class
• radiated field (IEC 61000-4-3)	IV class
• electrical fast transient / burst (IEC 61000-4-4)	IV class
• surge (IEC 61000-4-5)	IV class
• conducted (IEC 61000-4-6)	IV class
• power frequency magnetic fields (IEC 61000-4-8)	III class
• voltage dips (IEC 61000-4-11)	III class

### Description

Electric energy meters **RLE01-2M** are designed for direct mounting on 35 mm rail mount acc. to EN 60715. Thanks to the modular design of the cover, they are characterized by ergonomic installation in distribution cabinets, as well as small size, light weight, easy installation and reliability. They have fireproof housing (ABS), good impact resistance, high temperature resistance, excellent insulation and durability.

According to Directive 2014/32/EU, they are de-signed for installation in "M1" mechanical environment, where shock and vibration are of minor importance, and for installation in "E2" electromagnetic environment.

The meters are designed for real, accurate measurement of the user's electricity consumption, this is done through the use of SMT technology integrated circuit along with advanced digital sample processing modules.

They realize the measurement of the following parameters: voltage, current, active current, reactive current, active power, reactive power, apparent power, power factor, frequency, demand, maximum value, minimum value. Other energy measurement functions are: bi-directional active energy measurement, bi-directional reactive energy measurement, four-quadrant reactive energy, apparent energy.

The meter provides pulse output of active energy and adopts open collector optical mode to realize remote transmission of active energy. A remote computer terminal, PLC and switching signal acquisition module are used to collect the energy.

### Connection diagrams

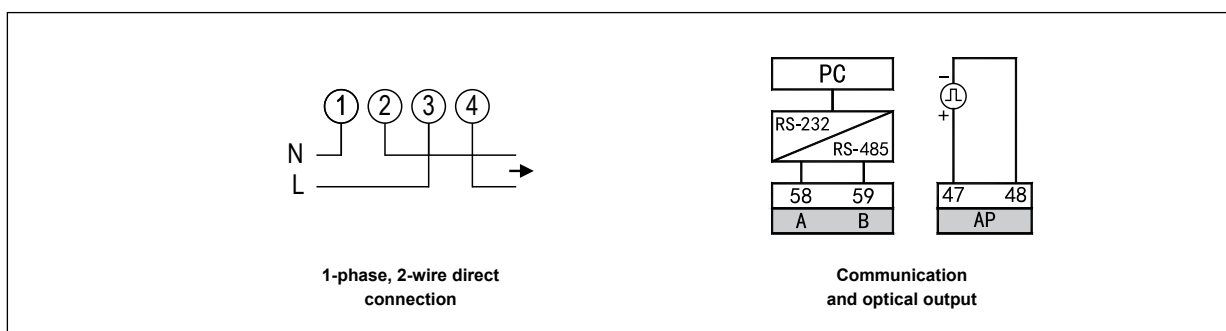







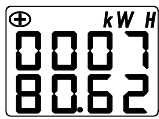
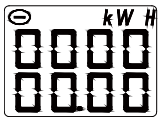
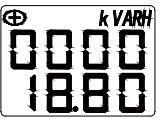
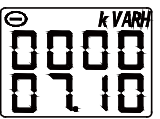

# RLE01-2M

electric energy meters

## Display interfaces

Switch between different display interfaces: press  $\leftarrow$  and  $\rightarrow$ .

Energy display			
 <p>Active energy import: EP = 780,62 kWh</p>	 <p>Active energy export: EP- = -0,00 kWh</p>	 <p>Reactive energy import: EQ = 18,8 kvarh</p>	 <p>Reactive energy export: EQ- = -7,1 kvarh</p>
Display of electrical variables			
 <p>Voltage: U = 220 V</p>	 <p>Current: I = 35 A</p>	 <p>Active power: P = 7,7 kW</p>	 <p>Reactive power: Q = -0,006 kvar</p>
 <p>Apparent power: S = 7,7 kVA</p>	 <p>Power factor: PF = 1</p>	 <p>Frequency: F = 50 Hz</p>	

## Dimensions

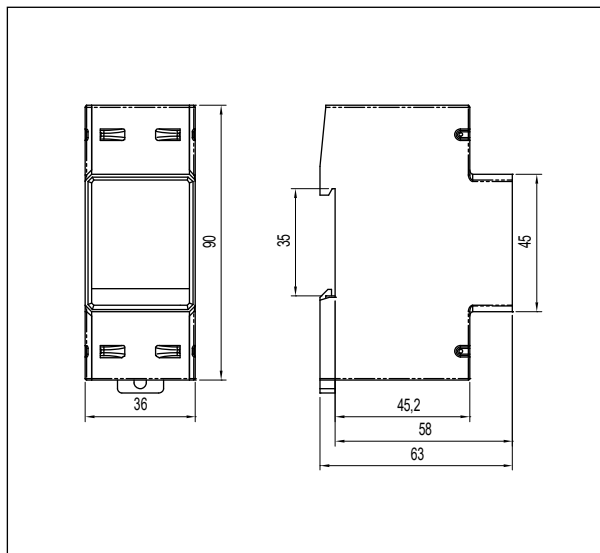

## Front panel description

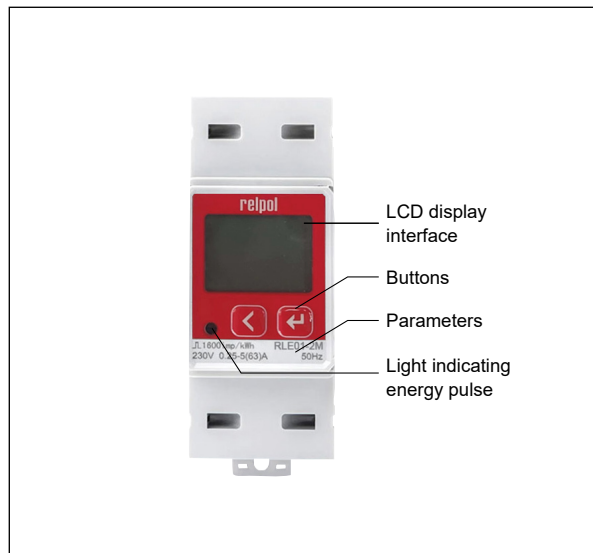

# RLE01-2M

electric energy meters

## Mounting

Meters **RLE01-2M** are designed for direct mounting on 35 mm rail mount acc. to EN 60715. Operational position - vertical.

**Catch:**  
easy mounting on 35 mm rail,  
firm hold (bottom).

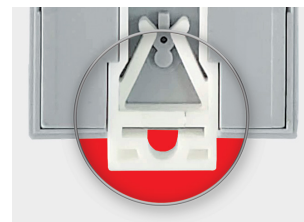

## Ordering codes

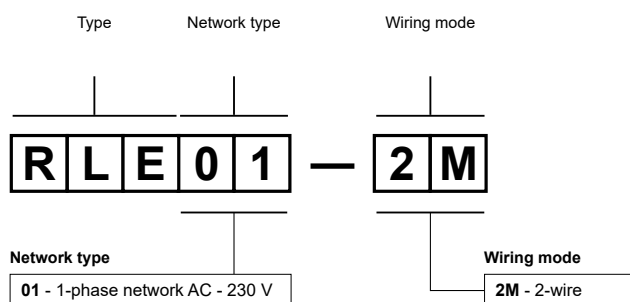

Example of ordering codes:

**RLE01-2M** meter **RLE01-2M**, cover - modular, width 36 mm, 2-wire wiring, electric energy measurement in 1-phase network AC - 230 V 50/60 Hz

### PRECAUTIONS:

1. Ensure that the parameters of the product described in its specification provide a safety margin for the appropriate operation of the device or system and never use the product in circumstances which exceed the parameters of the product. 2. Never touch any live parts of the device. 3. Ensure that the product has been connected correctly. An incorrect connection may cause malfunction, excessive heating or risk of fire. 4. In case of any risk of any serious material loss or death or injuries of humans or animals, the devices or systems shall be designed so to equip them with double safety system to guarantee their reliable operation.